

**Physics 106: Electricity and Magnetism I**  
**Spring Semester, 2010**

**PROBLEM SET 6: Due Friday, March 26.**

**Problem 1:** Purcell 4.27

**Problem 2:** Purcell 4.33

**Problem 3:** An initially uncharged capacitor  $C = 1.80 \mu\text{F}$  (micro-farads  $10^{-6} \text{ F}$ ) is charged up by a battery producing a constant EMF of  $11 \text{ V}$  in series with a resistor  $R = 142 \text{ M}\Omega$  (mega-ohms:  $10^6 \Omega$ ).

- (a) Calculate the time constant.
- (b) Find the maximum charge that will appear on the capacitor during charging.
- (c) How long does it take for the charge to build up to  $15 \mu\text{C}$ ?
- (d) Show that the energy stored in the capacitor when fully charged is half of the total energy supplied by the battery.

**Problem 4:** consider the circuit in Fig. 1. The switch is open for  $t < 0$  and closed for  $t \geq 0$ .

- (a) Determine currents the currents flowing into each capacitor immediately before and immediately after closing the switch.
- (b) Determine the currents flowing into each capacitor for  $t \rightarrow \infty$ .
- (c) Qualitatively sketch the current through one of the capacitors as a function of time.
- (d) Set up differential equations needed to determine all capacitor currents.
- (e) **10 point Bonus Question:** Based on your answer to (c), introduce assumptions for the time dependent currents into the differential equation and determine the time constants. (note there will be different time constants for each capacitor.)

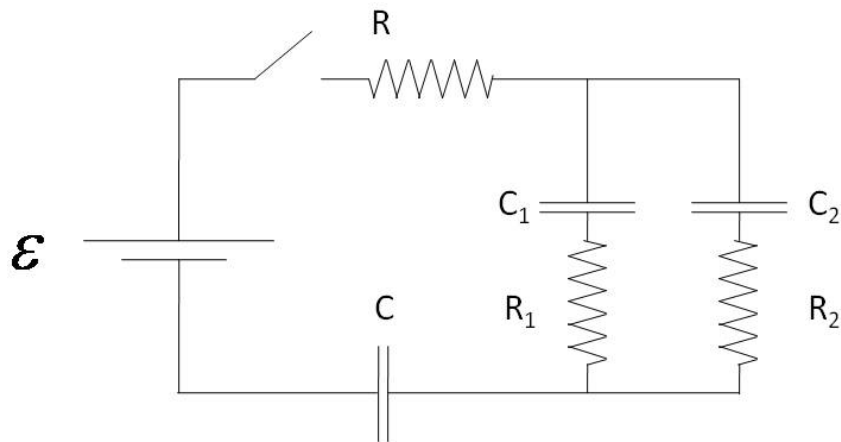

**Problem 5:** Purcell 2.15

**Problem 6:** Purcell 6.1